

Commensurators of Some Non-uniform Tree Lattices and Moufang Twin Trees

Peter Abramenko¹ and Bertrand Rémy²

¹Department of Mathematics, Institut Camille Jordan – UMR CNRS, University of Virginia, Université Claude Bernard – Lyon 1, P.O. Box 400137, Charlottesville
²21 rue Claude Bernard, VA 22904 4137 – USA, 69622 Villeurbanne cedex, France
e-mail: pa8e@virginia.edu; remy@math.univ-lyon1.fr

Abstract. Sh. Mozes showed that the commensurator of the lattice $\mathrm{PSL}_2(\mathbf{F}_p[t^{-1}])$ is dense in the full automorphism group of the Bruhat–Tits tree of valency $p + 1$, the latter group being much bigger than $\mathrm{PSL}_2(\mathbf{F}_p((t)))$. By G.A. Margulis’s criterion, this density is a generalized arithmeticity result. We show that the density of the commensurator holds for many tree-lattices among those called of Nagao type by H. Bass and A. Lubotzky. The result covers many lattices obtained via Moufang twin trees.

Keywords. Tree, lattice of Nagao type, commensurator, twinning, Moufang property Kac-Moody group.

Subject Classification: 22F50, 22E20, 51E24, 22E40

Introduction

Tree lattices have been and still are the subject of a lot of interesting mathematical research, see in particular the monograph [BL01] and the papers cited there. One of the important issues is to find analogies – or to establish the differences – between lattices in the automorphism groups of locally finite trees and lattices in semisimple Lie groups (i.e. in semisimple algebraic groups over local fields). These questions are particularly relevant when the Lie groups are of rank 1. A fundamental theorem due to G.A. Margulis characterizes arithmetic lattices among lattices in semisimple Lie groups as those which are of infinite index in their commensurators [Mar91, Chapter IX, Theorem B]. (G.A. Margulis proved this characterization for finitely generated lattices, which excluded non cocompact lattices in rank 1 semisimple Lie groups over local fields with positive characteristic. A proof for this remaining case was later given by L. Lifschitz [Lif03].) G.A. Margulis also showed that being of infinite index in its commensurator already means that the commensurator of the lattice is $\langle\langle$ essentially $\rangle\rangle$ dense in the semisimple Lie group, and is in fact dense if the Lie group is simply connected (for a precise statement, see [Mar91, Chapter IX, Lemma 2.7]).

These results in the Lie group case motivated (among other things) the study of commensurators of tree lattices. In order to fix the ideas, we shall introduce some notation now. Let T be a locally finite tree with vertex set VT , and let $G := \mathrm{Aut}(T)$

be its group of automorphisms. Provided with the usual topology (a basis of open neighborhoods of the identity are the fixators of finite subtrees of T), the group G is locally compact. A T -lattice is by definition a lattice in G , i.e. a discrete subgroup of G of finite covolume. It is standard knowledge [BL01, Sections 1.5 and 3.2] that a subgroup Γ of G is a lattice in G if and only if all stabilizers $\Gamma_x, x \in VT$, are finite, as well as the sum $\text{Vol}(\Gamma \backslash T) := \sum_{x \in \Gamma \backslash VT} |\Gamma_x|^{-1}$ is finite. We call Γ a *uniform* (resp. *non-uniform*) T -lattice if the quotient $\Gamma \backslash T$ is finite (resp. infinite). The *commensurator* of Γ in G is the group defined as: $\text{Comm}_G(\Gamma) := \{g \in G \mid \Gamma \cap g\Gamma g^{-1} \text{ has finite index in } \Gamma \text{ and in } g\Gamma g^{-1}\}$ and will be abbreviated by $C(\Gamma)$ in the following. Interesting questions concerning $C(\Gamma)$ are the following:

Question 1. Is Γ of infinite index in $C(\Gamma)$?

Question 2. Is $C(\Gamma)$ (essentially) dense in G ?

As mentioned above, these two questions are equivalent for lattices in semisimple Lie groups, but it is known that they are not equivalent for tree lattices [BL01, Section 10.3]. So it is not quite clear which of the two conditions should be used to define, by analogy, $\langle\langle$ arithmetic $\rangle\rangle$ tree lattices. Usually one chooses the stronger condition and considers a tree lattice Γ as *arithmetic* if $C(\Gamma)$ is dense in G . An important theorem proved by Y. Liu states that all uniform tree lattices are arithmetic in the latter sense [Liu94]. Much less is known about commensurators of non-uniform tree lattices. In particular, to the best of our knowledge, only two examples of non-uniform tree lattices with dense commensurators are discussed in the literature, namely the example given in [BM96, Section 8.3] and the Nagao lattice $\text{PSL}_2(\mathbf{F}_p[t^{-1}])$ which is shown in [Moz99] to have a dense commensurator for any prime number p .

It is the main objective of the present paper to generalize the two last mentioned examples in two directions. Firstly, both examples are *lattices of Nagao type* in the sense of [BL01, Chapter 10]. For a tree lattice Γ of Nagao type, we have a natural *level function* $\ell : VT \rightarrow \mathbf{N}$ which is Γ -invariant (see Definition 11 below), and we set $L := \{g \in G \mid \ell(g \cdot x) = \ell(x) \text{ for all } x \in VT\}$. Now the following question is crucial with respect to the examples discussed in [BM96] and [Moz99].

Question 3. Is $C(\Gamma) \cap L$ dense in L ?

In Section 4.2 of this paper, we shall give a positive answer to this question for all lattices of *directly split Nagao type*, a class of lattices which we shall introduce in Section 4.1 below. This is our:

Theorem 4. *If Γ is a tree lattice of directly split Nagao type, then $C(\Gamma) \cap L$ is dense in L .*

Referring the reader to Section 4.1 for some technical details concerning lattices of directly split Nagao type, we just mention that this class of lattices is much larger than the examples discussed in [BM96] and [Moz99]. In particular, we allow arbitrary finite $\langle\langle$ root groups $\rangle\rangle$ whereas the root groups in [loc. cit.] are always cyclic. (For the classical Nagao lattice $\text{PSL}_2(\mathbf{F}_q[t^{-1}])$ the root groups are isomorphic to the additive group of \mathbf{F}_q , hence cyclic if and only if q is a prime number.)

Now if the tree T is not biregular, then one easily checks that $L = G$ (Lemma 16), and hence a positive answer to Question 3 already means that $C(\Gamma)$ is dense in G . If, however, T is biregular (as in the case of the classical Nagao lattice), then we need a second ingredient in order to deduce the density of $C(\Gamma)$ from Theorem 4. Generalizing a strategy used by Sh. Mozes in [Moz99], we can show that $C(\Gamma)$ is already essentially dense in G in the biregular case if it is not contained in L . More precisely, denoting by G° the subgroup (of index at most 2) of G of all type-preserving automorphism of T (preserving the 2-colouring of T), we obtain:

Theorem 5. *If Γ is a T -lattice of directly split Nagao type with biregular T and $C(\Gamma)$ is not contained in L , then the closure of $C(\Gamma)$ in G contains G° .*

In general it is of course difficult to decide whether $C(\Gamma)$ is included in L or not. In the case of $\Gamma = \mathrm{PSL}_2(\mathbf{F}_q[t^{-1}])$, the additional ingredient that Sh. Mozes used was the transitive action of $C(\Gamma)$ on the set of edges of T . This transitivity property follows here, for the truly arithmetic group Γ , from the fact that its commensurator contains $\mathrm{PSL}_2(\mathbf{F}_q(t))$, an argument which is not available for other lattices of Nagao type. This brings us to our second line of generalization.

A special class of lattices of Nagao type arises from the theory of twin trees as follows. Let a locally finite (thick) twin tree (T_\pm, δ^*) be given which has the Moufang property (for definitions, see Section 4.3 below). We remark that the trees T_+ and T_- are necessarily biregular. Denote by A the automorphism group of the twin tree (T_\pm, δ^*) and by Λ its subgroup generated by all root groups. Fix a vertex of T_- and denote by Γ its stabilizer in Λ . Then it is well-known that Γ acts on T_+ as a non-uniform T_+ -lattice with a ray R as fundamental domain. Moreover, Γ is always a lattice of Nagao type in the sense of [BL01], and it is of directly split Nagao type in our sense if it satisfies the following condition (which will also be explained in more detail in Section 4.3).

Assumption 6 (Comm). *For any prenilpotent pair $\{a; b\}$ of twin roots of the Moufang twin tree (T_\pm, δ^*) , the corresponding root groups U_a and U_b commute.*

It is not difficult to check that A is contained in the commensurator of the T_+ -lattice Γ and that it acts transitively on the set of all (geometric) edges of T . In particular, $C(\Gamma)$ is not contained in L , and thus Theorem 5 implies (where G° denotes the group of all type-preserving automorphisms of T_+):

Theorem 7. *If the thick locally finite Moufang twin tree (T_\pm, δ^*) satisfies (Comm) and Γ is the T_+ -lattice described above, then the closure of $C(\Gamma)$ contains G° . Therefore $C(\Gamma)$ is dense in G if T_+ is not regular and also, in the regular case, if A contains an automorphism interchanging the types of vertices.*

First examples for groups Λ and Γ satisfying (Comm) come from rank 2 Kac-Moody groups over finite fields (see 4.3.4). As a special (affine) case we obtain $\Lambda = \mathrm{PSL}_2(\mathbf{F}_q[t, t^{-1}])$ and $\Gamma = \mathrm{PSL}_2(\mathbf{F}_q[t^{-1}])$ for any prime power q . In the latter case, the matrix $\begin{pmatrix} t & 0 \\ 0 & 1 \end{pmatrix} \in \mathrm{PGL}_2(\mathbf{F}_q[t])$ provides an element of A interchanging the vertex types: it acts on the tree as a hyperbolic translation, and its translation length is the length of a single edge. The construction of more exotic examples is sketched in

Example 69. As a very special case, we consider trees of constant degree equal to 7. For a non-uniform tree-lattice Γ naturally defined in terms of twinings, the density of the commensurator holds, at least in the index 2 subgroup G° . Note that in this case the full automorphism group G is $\langle\langle$ as big as $\rangle\rangle$ in the case considered by Sh. Mozes, in the sense that the tree of valency 7 is $\langle\langle$ as homogeneous as $\rangle\rangle$ a Bruhat-Tits tree of some $\mathrm{PSL}_2(\mathbf{F}_p((t)))$. Nevertheless, the case is new at least because it can easily be proved that the lattice itself cannot be linear over a field.

We close this introduction by an open question relevant to a higher-dimensional generalization of the above results.

Question 8. Let Δ_\pm be a locally finite thick Moufang twin building whose apartments are right-angled tilings of the hyperbolic plane. Does the non-uniform lattice naturally defined as a negative chamber stabilizer have a dense commensurator in $\mathrm{Aut}(\Delta_+)$?

We focus on the case of right-angled Fuchsian buildings because the local product structure of the links at vertices implies the existence of many symmetries for this class of buildings. Therefore the corresponding full automorphism groups are big topological groups. Recent results by F. Haglund on commensurators of some uniform lattices for hyperbolic buildings [Hag03] are analogous to Y. Liu's theorem for trees (and might be used as such). Note that concrete examples of right-angled Fuchsian buildings admitting a twinning are available [RR06, Theorem 4.E.2].

This paper is organized as follows. Section 4.1 deals with lattices of Nagao type as introduced by H. Bass and A. Lubotzky. The subclass of tree-lattices of directly split Nagao type is introduced (4.1.2) and the condition defining it is characterized in terms of actions on some horoballs (4.1.3). Section 4.2 proves the main density result (Theorem 4), following the ideas presented in [BM96, Section 8.3]. The main change with respect to [BM96] and [Moz99] is the replacement of local data by purely group-theoretic considerations (4.2.3). Section 4.3 recalls some facts about Moufang twin trees, and then describes the intersection of this theory with that of tree-lattices of Nagao type. This shows in particular that the class of non-uniform tree-lattices to which Theorem 5 applies is quite wide (4.3.4).

We thank Sh. Mozes for helpful discussions on Example 69 and are very grateful to the organizers of the conference $\langle\langle$ Geometric Group Theory $\rangle\rangle$ (Guwahati, Assam – India, December 2002) organized by the Indian Institute of Technology Guwahati and the Indian Statistical Institute (supported by the National Board of Higher Mathematics). The conference gave the authors the opportunity to complete their research on the subject which is presented in this paper.

4.1. Lattices of Nagao type

The tree lattices we are discussing in this paper are always fundamental groups of rays of groups. More precisely, we shall work with the following set-up.

Notation 9. Let R be an infinite ray with vertices $\{x_i\}_{i \geq 0}$. To each vertex x_i , $i \geq 0$, we attach a finite group Γ_i such that Γ_i is a subgroup of Γ_{i+1} for all $i > 0$. Furthermore, we are given a common subgroup H_0 of Γ_0 and Γ_1 . We define the integers $k := [\Gamma_0 :$

H_0], $q_0 := k - 1$, $q_1 := [\Gamma_1 : H_0]$ and $q_i := [\Gamma_i : \Gamma_{i-1}]$ for $i \geq 2$, and we require that $q_i \geq 2$ for all $i \geq 0$. Now we attach H_0 to the edge $\{x_0, x_1\}$ of R and Γ_i to $\{x_i, x_{i+1}\}$ for all $i > 0$. We have thus defined a graph of groups, where the graph is the ray R .

Picture 10.

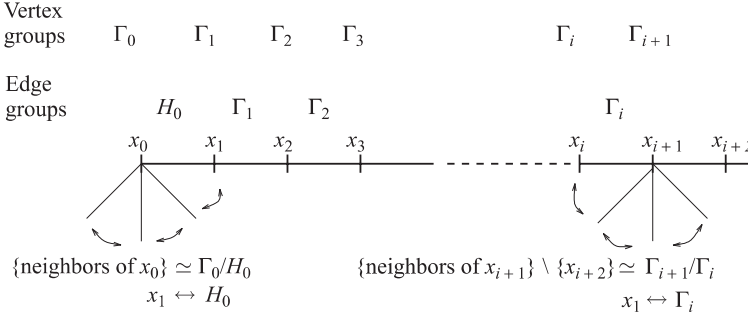

4.1.1. Levels, degrees and a first density result

Denote by Γ the fundamental group of this graph of groups and by T the canonical tree provided by Bass–Serre theory [Ser77, I.5.1]: Γ acts on T with R as a fundamental domain. For any $i \geq 0$, we identify Γ_i with the vertex stabilizer $\text{Stab}_\Gamma(x_i)$ and $H_0 = \Gamma_0 \cap \Gamma_1$ with the edge stabilizer $\text{Stab}_\Gamma(\{x_0, x_1\})$.

Definition 11. Any vertex $x \in VT$ lies in a Γ -orbit $\Gamma \cdot x_i$ for precisely one $i \geq 0$; we call i the level of x and denote it by $\ell(x) = i$. We set $G := \text{Aut}(T)$ and $L := \{g \in G \mid \ell(g \cdot x) = \ell(x) \text{ for all } x \in VT\}$.

The kernel of the canonical homomorphism $\Gamma \rightarrow G$ is a (finite) subgroup of H_0 , and by a slight abuse of notation, we shall denote the image of Γ in G again by Γ . Therefore Γ is a discrete subgroup of G , and it is of course also a subgroup of L . Our assumption $q_i \geq 2$ for all $i \geq 0$ implies that $\text{Vol}(\Gamma \backslash T) = \sum_{i=0}^{\infty} |\Gamma_i|^{-1}$ is finite. Hence Γ is an (obviously non-uniform) T -lattice, called a *lattice of Nagao type* in [BL01, Chapter 10]. Since R is a fundamental domain for the action of Γ on T , we immediately obtain the following two facts.

Fact 12. Each vertex $x \in VT$ of level 0 has precisely $k = q_0 + 1$ neighbors, and all of them are of level 1. In particular, the degree (or valency) of x is $\deg(x) = k$. □

Fact 13. Each vertex $x \in VT$ with $\ell(x) = i > 0$ has precisely 1 neighbor of level $i + 1$ and q_i neighbors of level $i - 1$. In particular, $\deg(x) = q_i + 1$. □

Fact 13 immediately implies the following two statements.

Fact 14. If $\{y_j\}_{j \geq 0} \subset VT$ is a geodesic ray in T with $\ell(y_0) > \ell(y_1)$, then for any $j \leq \ell(y_0)$, we have: $\ell(y_j) = \ell(y_0) - j$. □

Fact 15. If $y \in VT$ has level $i > 0$, then there is a unique (infinite) ray $R(y) = (y_0, y_1, \dots)$ starting in $y = y_0$ such that $\ell(y_j) = i + j$ for all $j \geq 0$. The ray $R(y)$ will be referred to as the level-increasing ray from x . □

It is well-known that either T is biregular (i.e. $\deg(x) = \deg(y)$ for any two vertices $x, y \in VT$ at even distance from each other) or $G \setminus T = R$ [BL01, Section 10.1]. However, we shall give a short elementary argument for this (in fact for a slightly more general) statement here, also because we shall later need the remark following this lemma.

Lemma 16. *If F is a subgroup of G which contains Γ and is not included in L , then $F \cdot x_0 = F \cdot x_{2m}$ and $F \cdot x_1 = F \cdot x_{2m+1}$ for all integers $m \geq 0$. Hence in this case T has to be biregular, and F acts transitively on vertices of the same type (i.e. at even distance from each other) and on the set ET of (geometric) edges of T .*

Proof. Since for any $x \in VT$, $\ell(x)$ is equal to the distance of x from the orbit $\Gamma \cdot x_0$, F acts level-preservingly on T if it stabilizes $\Gamma \cdot x_0$. Since F is not included in L , there is an $n > 0$ with $F \cdot x_0 = F \cdot x_n$. We choose $n > 0$ minimal with this property. If $n = 1$, we inductively get $F \cdot x_r = F \cdot x_{r-1} = F \cdot x_0$ for all $r \in \mathbf{N}$. If $n = 2$, then inductively $F \cdot x_3 = F \cdot x_1$, $F \cdot x_4 = F \cdot x_0 (= F \cdot x_2)$, $F \cdot x_5 = F \cdot x_1$ and so on.

Now assume that $n > 2$. Since $F \cdot x_{n-1} = F \cdot x_1$, we can choose a $g \in F$ with $g \cdot x_{n-1} = x_1$. Since $g \cdot x_n \neq x_2$ (otherwise $F \cdot x_2 = F \cdot x_n = F \cdot x_0$, contradicting the minimality of n), $\ell(g \cdot x_n) = 0$ by Fact 13. Now x_1 has $q_1 \geq 2$ neighbors of level 0, and Γ_1 acts transitively on them. Hence we can choose $\gamma_1 \in \Gamma_1$ such that $\gamma_1 \cdot (g \cdot x_n) \neq g \cdot x_n$. Hence $f := g^{-1}\gamma_1 g$ is in $F_{x_{n-1}}$ and $f \cdot x_n \neq x_n$. Therefore $\Gamma_{n-1}f \cdot x_n$ contains x_{n-2} , and thus $F \cdot x_{n-2} = F \cdot x_n = F \cdot x_0$. However, this again contradicts the minimality of n , and so $n > 2$ is impossible.

This proves the first claim, which immediately shows that F acts transitively on vertices of the same type. In particular, for any edge $e \in ET$, there is an $f \in F$ such that $x_0 \in f \cdot e$, and then there is a $\gamma_0 \in \Gamma_0$ such that $(\gamma_0 \cdot f) \cdot e = \{x_0, x_1\}$. Hence F acts transitively on ET . \square

Remark 17. It is not needed in the above argument that R is infinite. So if we have the same set-up as above, only with a finite path R' instead of R , and if T' and G' are defined similarly, then also T' has to be biregular or else $G' \setminus T' = R'$.

Lemma 18. *Any level-preserving isomorphism $\psi : T_1 \rightarrow T_2$ between two subtrees T_1 and T_2 of T extends to an element of L .*

Proof. By Zorn's lemma it suffices to show that ψ can always be properly and level-preservingly extended if $T_1 \neq T$. That this is in fact true can readily be checked by using the Facts 12 and 13 above. \square

Remark 19. This lemma in particular shows that the group L is non-discrete and uncountable.

The elementary statements which we deduced above have an interesting consequence if we combine them with an idea presented in the last paragraph of Mozes' paper [Moz99]. Recall that G° denotes the group of type-preserving automorphisms of T .

Proposition 20. *If F is a subgroup of G properly containing L (so that T must be biregular), then the closure of F in G contains G° .*

Proof. We have to show that any type-preserving isomorphism $\phi : S_1 \rightarrow S_2$ between two finite subtrees S_1 and S_2 of T can be extended to an element of F . Without loss of generality, we may assume that $S_1 = B_s(z_1)$, $S_2 = B_s(z_2)$ are two balls of radius $s \in \mathbb{N}$ with centers z_1 and z_2 which are of the same type. Let v_1 be a terminal vertex in S_1 and set $v_2 = \phi(v_1)$. So also v_1 and v_2 are of the same type. Let u_j ($j = 1, 2$) be the unique neighbor of v_j in S_j . Choose a vertex $x_n \in R$ of the same type as v_1 and v_2 with $n \geq 2s$. By Lemma 16, there exist elements $f_j \in F$ satisfying $f_j \cdot v_j = x_n$ and $f_j \cdot u_j = x_{n-1}$ for $j = 1, 2$. Set $T_j := f_j(S_j)$ for $j = 1, 2$, and consider the isomorphism $\psi := f_2|_{S_2} \phi f_1^{-1}|_{T_1} : T_1 \rightarrow T_2$. Note that ψ fixes x_n and x_{n-1} by construction. So Fact 14 together with $n \geq 2s$ implies that ψ is automatically level-preserving. Hence by Lemma 18, there exists a $g \in L$ satisfying $g|_{T_1} = \psi$. Therefore the element $f := f_2^{-1} g f_1 \in F$ extends ϕ . \square

4.1.2. Lattices of directly split Nagao type

Recall that we want to investigate the commensurator $C(\Gamma) = \{g \in G \mid \Gamma \cap g\Gamma g^{-1} \text{ has finite index in } \Gamma \text{ and in } g\Gamma g^{-1}\}$. In the present generality, we even cannot exclude the possibility that $C(\Gamma) = \Gamma$ (for such an example, see [BL01, Section 10.5]). Therefore we have to consider a restricted class of lattices of Nagao type. Motivated by and generalizing the discussion in [BM96, Section 8.3], we choose the following one.

Definition 21. *We say that the above introduced tree lattice Γ is of directly split Nagao type if there exist, for all $j > 0$, H_0 -invariant subgroups $U_j \leq \Gamma_j$, called root groups, such that $\Gamma_i = H_0 \rtimes (U_1 \times U_2 \times \cdots \times U_i)$ for all $i > 0$.*

Remark 22.

1. $\langle\langle$ Directly split $\rangle\rangle$ above refers to the direct products $U_1 \times U_2 \times \cdots \times U_i$. In view of this terminology one would perhaps expect that also the product with H_0 is direct. However, this would be too restrictive; it would even exclude the classical Nagao lattice $\text{PSL}_2(\mathbf{F}_q[t^{-1}])$.
2. The terminology $\langle\langle$ root group $\rangle\rangle$ is motivated by building theory (here: twin tree theory) and will be explained in Section 4.3.
3. If $H_0 = \{1\}$, our lattices of directly split Nagao type are the same as the *product groupings* associated to Nagao rays in [BL01, Section 10.6].
4. We stress again that our root groups U_i can be completely arbitrary non-trivial finite groups.
5. It would be desirable, especially in view of Moufang twin trees which do not satisfy the Condition (Comm), to obtain results as deduced below for splittings $\Gamma_i = H_0 \rtimes (U_1 \cdots U_i)$ which are not necessarily direct. However, our method really requires that the different root groups commute. We shall give a geometric characterization of this algebraic property in Lemma 31 below.

For the rest of this paper, we shall assume that our lattices are of directly split Nagao type. We start by collecting a few elementary statements, the first two of which are obvious.

Fact 23. We have: $\Gamma_1 = H_0 \times U_1$ and $\Gamma_i = \Gamma_{i-1} \times U_i$ for any $i \geq 2$. In particular, $|U_i| = q_i \geq 2$ for any $i \geq 1$. \square

Fact 24. For any $i > 0$, the group U_i acts simply transitively (i.e. regularly) on the set of neighbors of x_i which are different from x_{i+1} . \square

This can easily be generalized as follows.

Lemma 25. For any two integers i and j with $0 < i \leq j$, the group $U_{i,j} := U_i \times U_{i+1} \cdots \times U_j$ acts simply transitively on $M_{i,j} := \{x \in VT \mid \ell(x) = i - 1 \text{ and } \text{dist}(x, x_j) = j - i + 1\}$, where $\text{dist}(x, x_j)$ denotes the distance between x and x_j in T .

Proof. The fact that $U_{i,j}$ acts transitively on $M_{i,j}$ immediately follows from Fact 24 by induction on $j - i$. Now assume that an element $u = u_j \cdots u_i \in U_{i,j}$ fixes x_{i-1} . Since $U_{i,j} \leq \Gamma_j$, u has to fix x_l for all $i - 1 \leq l \leq j$. In particular, $x_{j-1} = u \cdot x_{j-1} = u_j \cdot x_{j-1}$, which implies $u_j = 1$, again by Fact 24. Going on this way, we get $u_j = u_{j-1} = \cdots = u_i = 1$. \square

Picture 26.

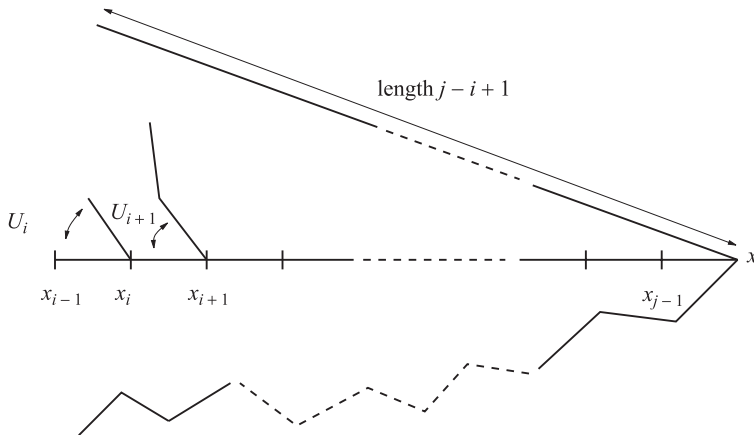

4.1.3. Horoballs and horospheres

Recall that to any end ϵ of the tree T , we can associate horospheres and horoballs centered at ϵ , see for instance [BL01, Section 9.2]. In the present paper, only certain horospheres and horoballs, defined by vertices of positive level, will play a role.

Definition 27. Let x be a vertex of level $\ell(x) > 0$, and let ϵ_x be the end of T defined by the level-increasing ray from x (see Fact 15).

- (a) We denote by $\text{HS}(x)$ the horosphere centered at ϵ_x which contains x .
- (b) We denote by $\text{HB}(x)$ the horoball centered at ϵ_x which has $\text{HS}(x)$ as its boundary, i.e. as its set of terminal vertices.

Remark 28. It is easy to see that the horoball $\text{HB}(x)$ is the connected component of x in the forest spanned by all vertices of level $\geq \ell(x)$, and that the horosphere $\text{HS}(x)$ is the set of vertices of level $\ell(x)$ in $\text{HB}(x)$.

The following statement is an immediate consequence of Lemma 25 and the above definition.

Fact 29. For any integer $i > 0$, the subgroup $W_{i+1} := \langle U_j \mid j \geq i+1 \rangle$ of Γ acts simply transitively on the horosphere $\text{HS}(x_i)$. \square

Remark 30. As opposed to Lemma 31 below, this fact remains true in a more general context (for instance for general Moufang twin trees), where the products $U_1 \dots U_i$ are not required to be direct.

We close this section by stating a geometric consequence of the directness of these products which will play an important role in the next section.

Lemma 31. *For any $i > 0$, the group U_i fixes the horoball $\text{HB}(x_i)$ pointwise.*

Proof. It suffices to show that U_i acts trivially on $\text{HS}(x_i)$. So take an arbitrary vertex $x \in \text{HS}(x_i)$, and let w be the unique element in W_{i+1} satisfying $x = w \cdot x_i$ (Fact 29). Now since U_i commutes with U_j for all $j > i$, it also commutes with W_{i+1} . Therefore $u_i \cdot x = u_i \cdot (w \cdot x_i) = w \cdot (u_i \cdot x_i) = w \cdot x_i = x$ for all $u_i \in U_i$. \square

4.2. Proof of the main density theorem

We are now going to investigate the commensurator $C(\Gamma)$, where Γ is a T -lattice of directly split Nagao type as introduced in Section 4.1. Let us first of all mention that Question 1 formulated in the introduction has a positive answer in this case. In fact, according to [BL01, Section 10.1], Γ is already of infinite index in $N_G(\Gamma)$, its normalizer in G . In this section, it is our goal to show that $C(\Gamma) \cap L$ is dense in L , which is the major step towards answering Question 2. Our strategy will be an appropriate adaptation (using more group theoretic constructions instead of $\langle\langle \text{local data} \rangle\rangle$) of the method developed in [BM96, Section 8.3]. In particular, we shall also prove an extension result for commensurators of certain uniform tree lattices for subtrees of T with bounded level function (see Proposition 54) and then apply Liu's theorem ([Liu94]).

As in [Moz99], it will be technically convenient to work with a certain finite index subgroup Δ of Γ (so that of course $C(\Delta) = C(\Gamma)$) instead of Γ itself. In the case of the classical Nagao lattice $\text{PSL}_2(\mathbb{F}_q[t^{-1}])$, Sh. Mozes used the first congruence subgroup. In the theory of Kac-Moody groups, one would analogously choose Δ to be the $\langle\langle \text{unipotent radical} \rangle\rangle$ of Γ , where Γ is considered as a parabolic subgroup of a Kac-Moody group over a finite field. In the next subsection we shall define Δ in terms of the subgroups U_i introduced in Definition 21.

4.2.1. The group Δ and its action on the tree and on horoballs

We keep the notations introduced in Section 4.1 and define further subgroups of the T -lattice Γ of directly split Nagao type. First, we call $V := \langle U_i \mid i > 0 \rangle = \bigoplus_{i>0} U_i$ the direct sum of the groups U_i when i ranges over all the positive integers i . We fix a

system $\{\gamma_1 := 1; \gamma_2; \dots; \gamma_k\}$ of representatives of the cosets in Γ_0/H_0 . For $i > 0$ and $1 \leq s \leq k$, we also set:

$$U_{i,s} := \gamma_s U_i \gamma_s^{-1} \quad \text{and} \quad V_s := \langle U_j, s | j > 0 \rangle = \gamma_s V \gamma_s^{-1},$$

so that $V_1 = V$, and we finally define $\Delta := \langle V_s | 1 \leq s \leq k \rangle$.

Lemma 32. *The group Δ is the normal closure of V in Γ , and we have: $\Gamma = \Gamma_0 \rtimes \Delta$.*

Proof. Recall that $\Gamma = \langle \Gamma_0 \cup V \rangle$ and that H_0 normalizes V . This implies $\Gamma = \Gamma_0 \Delta$ (since $V \Gamma_0 \Delta = \Gamma_0 \Delta$), and hence Δ is normal in Γ .

The definition of Γ as the fundamental group of a ray of groups implies that Γ is an amalgam of the form $\Gamma = \Gamma_0 *_{H_0} H_0 V$. Now the normal form for amalgams (as stated for instance in [Ser77, I.1.2]) shows that no product of the form $\gamma_{j_1} v_1 \gamma_{j_1}^{-1} \gamma_{j_2} v_2 \gamma_{j_2}^{-1} \dots \gamma_{j_l} v_l \gamma_{j_l}^{-1}$ with $l \in \mathbb{N}$, $v_1, \dots, v_l \in V \setminus \{1\}$, $1 \leq j_r \leq k$ for all $r \leq l$ and $j_r \neq j_{r+1}$ (hence $\gamma_{j_r}^{-1} \gamma_{j_{r+1}} \notin H_0$) for all $r < k$ is an element of Γ_0 . Hence $\Gamma_0 \cap \Delta = \{1\}$. \square

The same normal form argument also shows that $\Delta = V_1 * V_2 * \dots * V_k$.

Lemma 33. *For any positive integer $i > 0$, the stabilizer $\text{Stab}_\Delta(x_i)$ is equal to $U_1 \times U_2 \times \dots \times U_i$ and acts trivially on $\text{HB}(x_i)$.*

Proof. Since $H_0 \cap \Delta = \{1\}$ by the previous lemma, we obtain $\text{Stab}_\Delta(x_i) = \Gamma_i \cap \Delta = (H_0 \rtimes (U_1 \times U_2 \times \dots \times U_i)) \cap \Delta = U_1 \times U_2 \times \dots \times U_i$. The second assertion now follows from Lemma 31. \square

Remark 34. The triviality of the $\text{Stab}_\Delta(x_i)$ -action on $\text{HB}(x_i)$ is the main reason why we work with Δ instead of Γ : we do not have the same property for Γ_i since H_0 usually acts non-trivially on $\text{HB}(x_i)$.

Lemma 35. *The subtree $F := \Gamma_0 \cdot R$ is a fundamental domain for the Δ -action on T .*

Proof. We have: $\Delta \cdot F = (\Delta \cdot \Gamma_0) \cdot R = \Gamma \cdot R = T$. Now assume that there are $\delta \in \Delta$ and $g, h \in \Gamma_0$ and $i, j \geq 0$ such that $\delta \cdot (g \cdot x_i) = h \cdot x_j =: x$. Then first of all $i = j = \ell(x)$. Secondly, we may and shall assume $i > 0$ (otherwise $\delta = 1$ by Lemma 32). So $h^{-1} \delta g$ is in $\Gamma_i \subseteq \Delta H_0$. Since $h^{-1} \delta h \in \Delta$, we conclude that $h^{-1} g$ is also in ΔH_0 . However, $\Gamma_0 \cap \Delta \cdot H_0 = H_0$ by Lemma 32, so that $h^{-1} g \in H_0$. Therefore: $g \cdot x_i = h \cdot x_i = h \cdot x_j$. \square

This lemma shows in particular that Δ acts simply transitively on the set of all vertices of level 0. Using again the coset representatives $\{\gamma_1 := 1; \gamma_2; \dots; \gamma_k\}$ for Γ_0/H_0 , we see that F is the union of the k rays $R_s := \gamma_s \cdot R$ with $1 \leq s \leq k$. We number the vertices of R_s by $x_{i,s} := \gamma_s \cdot x_i$ for all $i \geq 0$ (so $x_{0,s} = x_0$ for all s and $x_{i,1} = x_i$ for all i).

Claim 36. For any $1 \leq s \leq k$ and $i > 0$, we have:

- (i) The group $\langle U_{j,s} | j > i \rangle$ acts simply transitively on $\text{HS}(x_{i,s})$.
- (ii) The stabilizer $\text{Stab}_\Delta(x_{i,s})$ is equal to $U_{1,s} \times \dots \times U_{i,s}$ and acts trivially on $\text{HB}(x_{i,s})$.

Proof. The first statement follows directly from Fact 29, and the second from $\text{Stab}_\Delta(x_{i,s}) = \gamma_s \text{Stab}_\Delta(x_i) \gamma_s^{-1}$ (here we use that Δ is normal in Γ) and Lemma 33. \square

Lemma 37. *For any vertex x of level > 0 , we have:*

- (i) *the group $\text{Stab}_\Delta(x)$ acts trivially on $\text{HB}(x)$;*
- (ii) *if δ, δ' are two elements in Δ with $\delta \cdot x = \delta' \cdot x$, then $\delta|_{\text{HB}(x)} = \delta'|_{\text{HB}(x)}$.*

Proof. (ii) is a straightforward consequence of (i), and (i) follows from combining Claim 36 and Lemma 35. \square

Given $x \in VT$ with $\ell(x) > 0$, we can now label the elements in $\text{HS}(x)$ by elements of Δ .

Definition 38.

- (a) *For $x = x_{i,s} \in F$ with $1 \leq s \leq k$ and $i > 0$ and for any $y \in \text{HS}(x)$, we define $\delta_{x,y}$ to be the unique element in $\langle U_{j,s} | j > i \rangle$ satisfying $\delta_{x,y} \cdot x = y$ (see Claim 36).*
- (b) *For arbitrary $x \in VT$ with $\ell(x) > 0$ and $y \in \text{HS}(x)$, we choose $\delta \in \Delta$ such that $\delta \cdot x \in F$ and set $\delta_{x,y} := \delta^{-1} \delta_{\delta(x), \delta(y)} \delta$.*

The definition in part (b) above makes sense thanks to:

Claim 39. The above introduced element $\delta_{x,y}$ is well-defined.

Proof. Assume that also $\delta' \cdot x \in F$ for some $\delta' \in \Delta$ and set: $z := \delta' \cdot x = x_{i,s} = \delta \cdot x$ (see Lemma 35). Then $\delta'' := \delta' \delta^{-1} \in \text{Stab}_\Delta(z) = U_{1,s} \times \cdots \times U_{i,s}$. So firstly, δ'' acts trivially on $\text{HS}(z) = \text{HS}(\delta \cdot x) = \delta \cdot \text{HS}(x)$ by Lemma 37, hence $\delta' \cdot y = \delta'' \cdot (\delta \cdot y) = \delta \cdot y$; and secondly δ'' commutes with $\langle U_{j,s} | j > i \rangle$, in particular with $\delta_{z, \delta(y)}$. (Here we use again that Γ is of *directly* split type.) Therefore $\delta'^{-1} \delta_{\delta'(x), \delta'(y)} \delta' = \delta^{-1} \delta''^{-1} \delta_{z, \delta(y)} \delta'' \delta = \delta^{-1} \delta_{\delta(x), \delta(y)} \delta$. \square

Having established this, it is easy to check the following calculation rules:

Lemma 40. *For $x \in VT$ with $\ell(x) > 0$ and $y \in \text{HS}(x)$, we have:*

- (i) $\delta_{x,y}$ is in Δ and $\delta_{x,y} \cdot x = y$;
- (ii) $h \delta_{x,y} h^{-1} = \delta_{h(x), h(y)}$ for all $h \in \Delta$;
- (iii) $\delta_{y,x} = \delta_{x,y}^{-1}$;
- (iv) $\delta_{y,z} \delta_{x,y} = \delta_{x,z}$ for all $z \in \text{HS}(x)$.

Proof. (i) is clear by definition. To prove (ii), we note that if $\delta \in \Delta$ is such that $\delta \cdot x \in F$, then we can choose $\delta h^{-1} \in \Delta$ in the definition of $\delta_{h(x), h(y)}$ in order to have $(\delta h^{-1}) \cdot (h \cdot x) = \delta \cdot x \in F$. Therefore, applying part (b) of Definition 38, we obtain: $\delta_{h(x), h(y)} = (\delta h^{-1})^{-1} \delta_{\delta(x), \delta(y)} (\delta h^{-1}) = h \delta_{x,y} h^{-1}$.

According to (ii), it is enough to prove (iii) and (iv) for $x \in F$. So assume $x = x_{i,s}$ with $i > 0$ and $1 \leq s \leq k$. Set $\delta := \delta_{x,y}^{-1}$, and observe that this is an element of $\langle U_{j,s} | j > i \rangle$ sending y to $x \in F$ as well as $\delta \cdot y = x$ to $\delta \cdot x$. So by part (a) of

Definition 38, $\delta = \delta_{\delta(y),\delta(x)}$. Therefore, now by part (b) of Definition 38, $\delta_{y,x} = \delta^{-1}\delta_{\delta(y),\delta(x)}\delta = \delta^{-1}\delta\delta = \delta = \delta_{x,y}^{-1}$, proving (iii). In order to verify (iv), we first note that, again by part (b) of Definition 38, $\delta_{y,z} = \delta^{-1}\delta_{\delta(y),\delta(z)}\delta = \delta^{-1}\delta_{x,\delta(z)}\delta$, which is an element of $\langle U_{j,s} | j > i \rangle$. Hence also $\delta_{y,z}\delta_{x,y}$ is an element of $\langle U_{j,s} | j > i \rangle$, and by (i), it sends x to z . Therefore, by part (a) of Definition 38, $\delta_{y,z}\delta_{x,y} = \delta_{x,z}$, proving (iv). \square

4.2.2. Connected components of bounded level

We are now going to generalize the strategy of [BM96, Section 8.3] to the present situation. We recall the definition of a certain graph G_i associated to T and a given level $i > 0$.

Definition 41. For $i > 0$, we denote by T_i the subforest of T spanned by all vertices of level $\leq i$. For any vertex x with $\ell(x) \leq i$, we denote by $C_i(x)$ the connected component of T_i containing x . We set

$$C_i := \{C_i(x) | x \in VT \text{ and } \ell(x) \leq i\},$$

and define a (simplicial) graph

$$G_i = (VG_i, EG_i) \quad \text{with vertex set } VG_i = C_i$$

by declaring a two element subset $\{X, Y\}$ of VG_i to be in the edge set EG_i if and only if there exist vertices $x \in X$, $y \in Y$ such that $\ell(x) = \ell(y) = i$ and $y \in \text{HS}(x)$.

Remark 42.

1. If $\{X, Y\} \in EG_i$, the vertices $x \in X$ and $y \in Y$ in the above definition are uniquely determined: they are the unique terminal vertices of X and Y , respectively, contained in any geodesic in T which starts in a vertex of X and ends in a vertex of Y .
2. If $X, Y \in C_i$ are given, there is a unique geodesic in G_i connecting them. It is obtained from an arbitrary geodesic p in T which connects a vertex of X to a vertex of Y by first intersecting p with T_i , yielding a disjoint union p' of geodesics in T_i , then replacing these subgeodesics of p' with their corresponding connected components in C_i (considered as elements of VG_i) and connecting the adjacent ones among them by edges in EG_i .
3. A path \mathcal{P} in G_i , i.e. a finite sequence $\mathcal{P} = (X_0, \dots, X_n)$ with $X_j \in C_i$ for all $j \leq n$ and $\{X_j, X_{j+1}\} \in EG_i$ for all $j < n$, is a geodesic in G_i if and only if X_{j+2} is neither equal nor adjacent to X_j for all $j \leq n - 2$. In fact, there is only one path \mathcal{P} between X_0 and X_n in G_i with this last mentioned property. This follows from the uniqueness of geodesics in T .

The elements $\delta_{x,y}$ introduced in the previous subsection now provide us with transformations $\tau_{X,Y}$ mapping $X \in C_i$ onto $Y \in C_i$.

Definition 43. Let $X, Y \in \mathcal{C}_i$ be given.

- (a) If X and Y are adjacent in G_i , and if $x \in VX$, $y \in VY$ are such that $y \in \text{HS}(x)$, we set $\tau_{X,Y} := \delta_{x,y}$. This is well-defined by Remark 42 (1).
- (b) If X and Y are arbitrary, we consider the unique geodesic $(X = X_0, X_1, \dots, X_n = Y)$ from X to Y in G_i , and set $\tau_{X,Y} := \tau_{X_{n-1}, X_n} \tau_{X_{n-2}, X_{n-1}} \cdots \tau_{X_0, X_1}$. We also set $\tau_{X,X} := 1$.

Remark 44. We note that $\tau_{X,Y} = \tau_{Z_{m-1}, Z_m} \tau_{Z_{m-2}, Z_{m-1}} \cdots \tau_{Z_0, Z_1}$ is true for any path $\mathcal{P} = (X = Z_0, Z_1, \dots, Z_m = Y)$ connecting X and Y in G_i . Indeed, if \mathcal{P} is not a geodesic, then by Remark 42 (3), there exists a subpath (A, B, C) of \mathcal{P} such that $A = C$ or $\{A, C\} \in EG_i$. In the first case, we delete B and $C = A$ from \mathcal{P} and observe that $\tau_{B,A} \tau_{A,B} = 1$ by Lemma 40 (iii). In the second case, we delete B from \mathcal{P} and note that $\tau_{B,C} \tau_{A,B} = \tau_{A,C}$ by Lemma 40 (iv). So simultaneously shortening the path \mathcal{P} and the product of τ 's associated to it without changing the value of this product, we finally obtain the geodesic between X and Y in G_i , and the associated product is precisely the one occurring in the above definition of $\tau_{X,Y}$.

Lemma 45. For any $X, Y, Z \in \mathcal{C}_i$, we have:

- (i) $\tau_{X,Y} \in \Delta$ and $\tau_{X,Y}(X) = Y$;
(ii) $h \tau_{X,Y} h^{-1} = \tau_{h(X), h(Y)}$ for all $h \in \Delta$;
(iii) $\tau_{Y,X} = \tau_{X,Y}^{-1}$;
(iv) $\tau_{Y,Z} \tau_{X,Y} = \tau_{X,Z}$.

Proof. The properties (i) to (iii) follow directly from the corresponding statements in Lemma 40, and (iv) is a consequence of Remark 44. \square

We close this subsection by introducing truncated versions of T , R , F and Δ . For $i > 0$, we set $Y_i := \mathcal{C}_i(x_0)$, $R^{(i)} := R \cap Y_i$, $F^{(i)} := F \cap Y_i = \Gamma_0 \cdot R^{(i)}$ and

$$\Delta_i := \langle U_{j,s} \mid 1 \leq j \leq i \quad \text{and} \quad 1 \leq s \leq k \rangle.$$

Lemma 46.

- (i) $R^{(i)}$ is a fundamental domain for the action of $\langle \Gamma_0 \cup \Gamma_i \rangle = \text{Stab}_\Gamma(Y_i)$ on Y_i ;
(ii) $F^{(i)}$ is a fundamental domain for the action of $\Delta_i = \text{Stab}_\Delta(Y_i)$ on Y_i ;
(iii) Δ_i (or more precisely: its image in $\text{Aut}(Y_i)$) is a uniform Y_i -lattice.

Proof. Set $\Gamma' := \langle \Gamma_0 \cup \Gamma_i \rangle$, which is obviously contained in $\text{Stab}_\Gamma(Y_i)$. It is clear that $\Gamma' \cdot R^{(i)}$ contains a neighborhood of $R^{(i)}$ in Y_i . Thus $\Gamma' \cdot R^{(i)}$ is open in Y_i . But as a subgraph of Y_i , it is also closed. Since Y_i is connected, we conclude $\Gamma' \cdot R^{(i)} = Y_i$. (Side remark: this kind of reasoning already occurs in [Ser77].) Thus $\Gamma' \backslash Y_i = R^{(i)}$. If $\gamma \in \Gamma$ stabilizes Y_i , then $\gamma \cdot x_j \in \Gamma' \cdot x_j$ for any $j \leq i$, and since $\text{Stab}_\Gamma(x_j) = \Gamma_j \subseteq \Gamma'$, we obtain $\gamma \in \Gamma'$. This proves (i).

The proof of (ii) is similar. We just observe that also $\Delta_i \cdot F^{(i)}$ (which contains a neighborhood of x_0 by definition of $F^{(i)}$) is open in Y_i due to the transitivity properties of the $U_{j,s}$ (see Fact 24). This implies $\Delta_i \cdot F^{(i)} = Y_i$ and hence $\Delta_i \backslash Y_i = F^{(i)}$. Since $\text{Stab}_\Delta(x) \subseteq \Delta_i$ for all vertices $x \in F^{(i)}$ (Claim 36 (ii)), we also obtain $\Delta_i = \text{Stab}_\Delta(Y_i)$. Finally, (iii) is an immediate consequence of (ii). \square

4.2.3. Permuting elements of the same level

We now replace the analysis of $\langle\langle \text{local data} \rangle\rangle$ which were used in [BM96] and [Moz99] by a more group theoretic construction. The latter is based on the observation Lemma 37 (ii) above and similar to the definition of the $\delta_{x,y}$. However, one has to be a bit careful here since Δ does not act transitively on the set of vertices of a given level.

Definition 47. For any given vertex x of level $i > 0$, let $s = s(x)$ be the unique integer with $1 \leq s \leq k$ and $x \in \Delta \cdot R_s$ (see Lemma 35).

- (a) We choose once and for all a $\delta_x \in \Delta$ such that $x = \delta_x \cdot x_{i,s} = (\delta_x \gamma_s) \cdot x_i$, and we set: $\gamma_x := \delta_x \gamma_s$.
- (b) For any two vertices x, y of the same level $i > 0$, we define: $\gamma_{x,y} := \gamma_y \gamma_x^{-1}$.

Note that we work with the fixed system of coset representatives $\{\gamma_1 := 1; \gamma_2; \dots; \gamma_k\}$ for Γ_0/H_0 and that $\gamma_{x,y}$ need not coincide with $\delta_{x,y}$ in case x and y are in the same horosphere (see, however, (iv) below which we will need to prove Claim 52).

Lemma 48. For vertices x, y, z of the same level $i > 0$, we have:

- (i) $\gamma_{x,y}$ is in Γ and $\gamma_{x,y} \cdot x = y$;
- (ii) $\gamma_{y,x} = \gamma_{x,y}^{-1}$;
- (iii) $\gamma_{y,z} \gamma_{x,y} = \gamma_{x,z}$;
- (iv) if $y \in \Delta \cdot x$ then $\gamma_{x,y} \in \Delta$.

Proof. (i), (ii) and (iii) are obvious by definition. If $x \in \Delta \cdot R_s$ and $y \in \Delta \cdot R_t$ with $1 \leq s, t \leq k$, then $\gamma_{x,y} \in \Delta \gamma_t \gamma_s^{-1} \Delta = \Delta \gamma_t \gamma_s^{-1}$ because $\Delta \triangleleft \Gamma$ (Lemma 32). This implies (iv). \square

The next property is a bit more subtle. It will be needed in order to obtain a reasonable definition of the groups L_i (see Definition 50 and Remark 51 (1)) which are essential for the extensions to be constructed in the next subsection.

Lemma 49. If x, y are vertices of level $i > 0$, $x' \in \text{HS}(x)$ and $y' := \gamma_{x,y}(x')$, then we have: $\gamma_{x,y}|_{\text{HB}(x)} = \gamma_{x',y'}|_{\text{HB}(x)}$.

Proof. By Lemma 48 (iii), we have: $\gamma_{x',y'} = \gamma_{y,y'} \gamma_{x,y} \gamma_{x',x}$. Since $x' \in \text{HS}(x)$ and hence $y' \in \gamma_{x,y} \cdot \text{HS}(x) = \text{HS}(y)$, $x' \in \Delta \cdot x$ and $y' \in \Delta \cdot y$ by the transitive action of Δ on $\text{HS}(x)$, respectively $\text{HS}(y)$ (combine Claim 36 and Lemma 35). Thus Lemma 48 (iv) tells us that $\gamma_{x',x}$ and $\gamma_{y,y'}$ are in Δ . Therefore $\gamma_{x',y'} \in \Delta \gamma_{x,y} \Delta = \gamma_{x,y} \Delta$, the last equality again following from $\Delta \triangleleft \Gamma$. Hence there exists a $\delta \in \Delta$ such that $\gamma_{x',y'} = \gamma_{x,y} \delta$. Since $\delta \cdot x' = \gamma_{x,y}^{-1} \gamma_{x',y'} \cdot x' = \gamma_{x,y}^{-1}(y') = x'$, we have $\delta \in \text{Stab}_\Delta(x')$. Therefore δ acts trivially on $\text{HB}(x') = \text{HB}(x)$ (Lemma 37), and finally: $\gamma_{x',y'}|_{\text{HB}(x)} = \gamma_{x,y} \delta|_{\text{HB}(x)} = \gamma_{x,y}|_{\text{HB}(x)}$. \square

4.2.4. Extensions and commensurators

We can now define suitable extensions of isomorphisms between subtrees $X, Y \in \mathcal{C}_i$ of T (see Proposition 53 below). For this we need to define certain subgroups of L .

Definition 50. Let $i > 0$ be a positive integer. By L_i we denote the group of all level-preserving automorphisms $h \in \text{Aut}(T)$ satisfying:

- (a) for any vertex x with $\ell(x) = i$, $h|_{\text{HB}(x)} = \gamma_{x,h(x)}|_{\text{HB}(x)}$;
- (b) for all $X, Y \in \mathcal{C}_i$, $(h\tau_{X,Y}h^{-1})|_{h(X)} = \tau_{h(X),h(Y)}|_{h(X)}$.

Remarks 51.

1. L_i is indeed a subgroup of L . If $g, h \in L_i$ then gh, h^{-1} clearly satisfy (b), and it follows from Lemma 48 that they also satisfy (a). In the extension procedure, we only need property (a) of the above definition at certain vertices x . However, one would not get a reasonable definition of L_i if one did not require (a) for all level i vertices x . But then one has to check that the different vertices in $\text{HS}(x)$ do not lead to different conditions for $h|_{\text{HB}(x)}$: this is precisely what we established in Lemma 49.
2. It is sufficient to require Condition (b) for a fixed $X_0 \in \mathcal{C}_i$ (and all $Y \in \mathcal{C}_i$). This follows from Lemma 45: $\tau_{X,Y} = \tau_{X_0,Y}\tau_{X_0,X}^{-1}$ for all $X, Y \in \mathcal{C}_i$.

Claim 52. For all $i > 0$, the group Δ is contained in L_i .

Proof. Condition (a) for elements of Δ follows from combining Lemma 37 (ii) and Lemma 48 (iv). Condition (b) follows from Lemma 45 (ii). \square

Up to replacing local data by the elements $\gamma_{x,y}$, the next proposition is similar to [BM96, Proposition 8.5].

Proposition 53. For any two $X, Y \in \mathcal{C}_i$ and any level-preserving isomorphism $h : X \rightarrow Y$, there is a unique extension of h to an automorphism $E(h) \in L_i$.

Proof. We first show how we can (and must) extend h to horoballs and elements of \mathcal{C}_i which are neighboring X .

- (1) *Definition of $E(h)$ on $\text{HB}(x)$.* According to Condition (a) of Definition 50, we have only one choice to define $E(h)$ on $\text{HB}(x)$ for $x \in VX$ with $\ell(x) = i$, namely by $E(h)|_{\text{HB}(x)} = \gamma_{x,y}|_{\text{HB}(x)}$, where $y := h(x)$.
- (2) *Definition of $E(h)$ on Z .* For $x \neq z \in \text{HS}(x)$, we set $Z := \mathcal{C}_i(z) \in \mathcal{C}_i$, $z' := E(h)(z) = \gamma_{x,y}(z)$ and $Z' := \mathcal{C}_i(z')$. Note that $z' \in \text{HS}(y)$. According to Condition (b) of Definition 50, we have to define $E(h)$ on Z by $E(h)|_Z = \tau_{Y,Z'}h\tau_{Z,X}|_Z$.
- (3) *Equality of the two definitions on $\{z\} = Z \cap \text{HB}(x)$.* Since $z' \in \text{HS}(y)$ and $z \in \text{HS}(x)$, Definition 43 implies $\tau_{Y,Z'}(y) = z'$ and $\tau_{Z,X}(z) = x$. Hence $\tau_{Y,Z'}h\tau_{Z,X}|_Z(z) = \tau_{Y,Z'}h(x) = \tau_{Y,Z'}(y) = z' = \gamma_{x,y}(z)$.
- (4) *Global definition of $E(h)$.* Now an easy induction along geodesics in G_i which start in X shows that we can, in precisely one way, extend the definition of $E(h)$ to horoballs and elements of \mathcal{C}_i in the neighborhood of \tilde{Z} for any $\tilde{Z} \in \mathcal{C}_i$ on which $E(h)$ is already defined. We thus get an automorphism $E(h)$ of T , and it is clear by construction that $E(h)$ is level-preserving.
- (5) *$E(h)$ is an element of L_i .* For any horoball $H = \text{HB}(v)$, ($v \in VT$ with $\ell(v) = i$), there is by construction of $E(h)$ a $z_1 \in HS = \text{HS}(v)$ such that $E(h)|_H =$

$\gamma_{z_1, z_2}|_H$, where $z_2 = E(h)(z_1)$. But then by Lemma 49, $E(h)|_H = \gamma_{w_1, w_2}|_H$ with $w_2 = E(h)(w_1)$ for all $w_1 \in HS$, yielding Condition (a) of Definition 50. To check Condition (b), we first consider an edge $\{A, B\}$ in G_i such that A is nearer to X than B , and set $A' = E(h)(A)$, $B' = E(h)(B)$. By the inductive definition of $E(h)$, we have $E(h)\tau_{A, B}E(h)^{-1}|_{A'} = \tau_{A', B'}|_{A'}$. Similarly for all edges on the geodesic in G_i between X and B . Applying Definition 43 to $\tau_{X, B}$, we now obtain $E(h)\tau_{X, B}E(h)^{-1}|_Y = \tau_{Y, B'}|_Y$. Since $B \in \mathcal{C}_i$ can be chosen arbitrarily, Remark 51 (2) implies that Condition (b) is also satisfied. \square

The next proposition shows that the above extension procedure is compatible with commensurators. This is [BM96, Proposition 8.6], which we reproduce to correct minor misprints and because we deal with the group Δ rather than Γ . We denote the fact that a subgroup N is of finite index in a group H by writing: $N <_{\text{f.i.}} H$. Since $\Delta <_{\text{f.i.}} \Gamma$, the commensurators $C(\Delta)$ and $C(\Gamma)$ of these groups in G coincide. We keep the notations $Y_i = C_i(x_0)$ and $\Delta_i = \text{Stab}_\Delta(Y_i)$ introduced in Lemma 46 and set $G_i := \text{Aut}(Y_i)$, $G'_i := \{h \in G_i \mid \ell(h \cdot x) = \ell(x) \text{ for all } x \in VY_i\}$.

Proposition 54. *Let $\bar{\Delta}_i$ be the natural image of Δ_i in G'_i . Then for any $g \in \text{Comm}_{G'_i}(\bar{\Delta}_i)$, the unique extension $E(g) \in L_i$ provided by Proposition 53 lies in the commensurator $\text{Comm}_L(\Delta) = C(\Delta) \cap L$.*

Proof. We first remark that the map $E : G'_i \rightarrow L_i$, $h \mapsto E(h)$ is a homomorphism by the uniqueness statement of Proposition 53. It is enough to show that for any $g \in \text{Comm}_{G'_i}(\bar{\Delta}_i)$, we have $\Delta \cap E(g)\Delta E(g)^{-1} <_{\text{f.i.}} \Delta$. (Indeed, apply it to g^{-1} and conjugate by $E(g)$ to deduce that $\Delta \cap E(g)\Delta E(g)^{-1} <_{\text{f.i.}} E(g)\Delta E(g)^{-1}$.) By definition of a commensurator, there is $\{\delta_j\}_{j=1}^r \subset \Delta_i$ such that, with $\bar{\delta}_j := \delta_j|_{Y_i}$, $\bar{\Delta}_i = \bigsqcup_{j=1}^r \bar{\delta}_j(\bar{\Delta}_i \cap g\bar{\Delta}_i g^{-1})$. It is enough to prove that we have: $\Delta = \bigcup_{j=1}^r \delta_j(\Delta \cap E(g)\Delta E(g)^{-1})$. Let $\delta \in \Delta$. Since $\tau_{\delta \cdot Y_i, Y_i} \circ \delta$ stabilizes Y_i , there is an index j such that $\bar{\delta}_j^{-1} \circ (\tau_{\delta \cdot Y_i, Y_i} \circ \delta)|_{Y_i} \in \bar{\Delta}_i \cap g\bar{\Delta}_i g^{-1}$. In particular, $\sigma := g^{-1} \circ (\delta_j^{-1} \circ \tau_{\delta \cdot Y_i, Y_i} \circ \delta)|_{Y_i} \circ g$ lies in $\bar{\Delta}_i$. Now we consider $E(g)^{-1}(\delta_j^{-1} \delta)E(g) \in L_i$ (recall that $\Delta \subseteq L_i$ by Claim 52) and prove that its restriction to Y_i coincides with the restriction of an element of Δ to Y_i . By uniqueness (Proposition 53), this will show that $E(g)^{-1}(\delta_j^{-1} \delta)E(g) \in \Delta$. The element δ being arbitrary in Δ , this will finally prove: $\Delta \cap E(g)\Delta E(g)^{-1} <_{\text{f.i.}} \Delta$. We are thus led to computing:

$$\begin{aligned} (E(g)^{-1}(\delta_j^{-1} \delta)E(g))|_{Y_i} &= E(g)^{-1}|_{\delta_j^{-1} \delta \cdot Y_i} \circ \delta_j^{-1}|_{\delta \cdot Y_i} \circ \delta|_{Y_i} \circ g \\ &= E(\bar{\delta}_j g)^{-1}|_{\delta \cdot Y_i} \circ \delta|_{Y_i} \circ g. \end{aligned}$$

We make σ appear on the right to obtain an element of $\bar{\Delta}_i$:

$$\begin{aligned} &= E(\bar{\delta}_j g)^{-1}|_{\delta \cdot Y_i} \circ ((\tau_{\delta \cdot Y_i, Y_i}|_{\delta \cdot Y_i})^{-1} \circ \bar{\delta}_j \circ g) \\ &\quad \circ (g^{-1} \circ \bar{\delta}_j^{-1} \circ \tau_{\delta \cdot Y_i, Y_i}|_{\delta \cdot Y_i}) \circ \delta|_{Y_i} \circ g \\ &= E(\bar{\delta}_j g)^{-1}|_{\delta \cdot Y_i} \circ ((\tau_{\delta \cdot Y_i, Y_i}|_{\delta \cdot Y_i})^{-1} \circ \bar{\delta}_j \circ g) \circ \sigma \\ &= (E(\bar{\delta}_j g)^{-1}|_{\delta \cdot Y_i} \circ \tau_{Y_i, \delta \cdot Y_i}|_{Y_i} \circ E(\bar{\delta}_j g)|_{Y_i}) \circ \sigma. \end{aligned}$$

Since $E(\bar{\delta}_j g) \in L_i$, this last product is $\tau_{Y_i, Z}|_{Y_i} \circ \sigma$, where $Z := E(\bar{\delta}_j g)^{-1}(\delta \cdot Y_i)$. Because $\tau_{Y_i, Z} \in \Delta$ and $\sigma \in \bar{\Delta}_i$, the restriction of $E(g)^{-1}(\bar{\delta}_j^{-1} \delta)E(g)$ to Y_i coincides with the restriction of an element of Δ to Y_i . \square

4.2.5. Density

We are now in a position to complete the proof of our main density theorem. The main tools will be Proposition 54 and Liu’s theorem on the arithmeticity of uniform tree lattices.

Proof of Theorem 4. Given any level-preserving isomorphism $\phi : T_1 \rightarrow T_2$ between two finite subtrees T_1 and T_2 of T , we have to find an element $h \in C(\Gamma) \cap L = C(\Delta) \cap L$ such that $h|_{T_1} = \phi$. We choose $i > 0$ big enough so that the subtree $Y_i = C_i(x_0)$ of T introduced in Lemma 46 satisfies the following two conditions:

- (i) the subtree Y_i contains $T_1 \cup T_2$;
- (ii) the tree Y_i is not biregular.

We briefly explain why Condition (ii) can always be achieved and why we need it. First recall that the vertices of level $j < i$ in Y_i have the same degree in Y_i as in T , namely $q_j + 1$ (Facts 12 and 13). And the vertices of level i are of degree q_i in Y_i . So either T is not biregular, and there exists an l such that $q_l \neq q_{l+2}$; then we choose $i > l + 2$. Or T is biregular, with degrees $q_0 + 1$ and $q_1 + 1$. In this case Y_i is not biregular for any $i \geq 2$. If Y_i is not biregular, then we know from Lemma 16, Remark 17 and Lemma 46 (i) that all automorphisms of Y_i are automatically level-preserving. This means $G'_i = G_i = \text{Aut}(Y_i)$ in the notation of Proposition 54.

Now $\bar{\Delta}_i$, the image of Δ_i in G_i , is a uniform Y_i -lattice (Lemma 46 (iii)). So by Liu’s theorem, the commensurator $\text{Comm}_{G_i}(\bar{\Delta}_i)$ is dense in $G_i = G'_i$. Hence there exists a $g \in \text{Comm}_{G'_i}(\bar{\Delta}_i)$ satisfying $g|_{T_1} = \phi$. By Proposition 53, g can be (uniquely) extended to an element $h := E(g)$ of L_i . Then Proposition 54 implies that $h \in C(\Delta) \cap L$, and by construction $h|_{T_1} = \phi$. \square

Theorem 4 has some immediate consequences which are worth to be mentioned. The first one is the generalization of the example discussed in [BM96, Section 8.3] to the class of all lattices of directly split Nagao type with associated non-biregular tree T . Recall that $L = G$ in these cases (see Lemma 16).

Corollary 55. *If Γ is a T -lattice of directly split Nagao type and T is not biregular, then $C(\Gamma)$ is dense in $G = \text{Aut}(T)$.* \square

The next corollary combines Theorem 4 and Proposition 20. It was stated as Theorem 5 in the introduction.

Corollary 56. *If Γ is a T -lattice of directly split Nagao type and T is biregular, then either $C(\Gamma)$ is a subgroup of L which is then dense in L or else the closure of $C(\Gamma)$ in G contains G° .* \square

For regular trees, this has the following immediate consequence.

Corollary 57. *If Γ is a T -lattice of directly split Nagao type such that T is regular and $C(\Gamma)$ contains a type-interchanging automorphism, then $C(\Gamma)$ is dense in G .*

If T is biregular, it is in general hard to see (and we do not know of any general method how to decide this question) whether $C(\Gamma)$ is included in L or not. However, there is one class of lattices of Nagao type where $C(\Gamma) \not\subseteq L$ is obvious, and this class of lattices we are going to discuss in the next section.

4.3. Applications to Moufang twin trees

We introduce Moufang twin trees and recall some decompositions available for groups acting on these trees: this enables us to connect this theory to the previous section. We also provide examples, from the Nagao lattice to more exotic twin trees, including generalized rank 2 Kac-Moody groups. General references for twin trees are [RT94], [RT99] and [Tit90, §9].

4.3.1. Twin trees without groups

The notion of codistance relating two trees can be introduced without reference to any group action [RT94, §1]. In this first subsection, we introduce as many notions as possible purely in combinatorial terms. We will show later how they coincide with previously defined objects in the Nagao context, when we have enough automorphisms.

Definition 58. *Let (T_{\pm}, δ^*) be a triple where T_+ and T_- are trees and where δ^* is a function with values in \mathbf{N} on pairs of vertices of opposite signs in $T_+ \sqcup T_-$. We say that (T_{\pm}, δ^*) is a twin tree or, equivalently, that δ^* is a codistance between T_+ and T_- if δ^* satisfies:*

(Codist) *For any $x_+ \in VT_+$ and any $y_- \in VT_-$, we have $\delta^*(y_-, x_+) = \delta^*(x_+, y_-)$, and furthermore, setting $m := \delta^*(x_+, y_-)$: for each $y'_- \in VT_-$ adjacent to y_- , one obtains $\delta^*(x_+, y'_-) = m \pm 1$; if $m > 0$ there is a unique y'_- such that $\delta^*(x_+, y'_-) = m + 1$; and we require the similar conditions with T_+ and T_- interchanged.*

In this case, we say that two vertices of opposite signs are opposite if their codistance is 0.

An automorphism of the twin tree (T_{\pm}, δ^) is a pair (α_+, α_-) of automorphisms of T_+ , respectively T_- , such that $\delta^*(\alpha_+(x_+), \alpha_-(y_-)) = \delta^*(x_+, y_-)$ for any $x_+ \in VT_+$ and any $y_- \in VT_-$. We denote the group of all automorphisms of (T_{\pm}, δ^*) by A .*

Two vertices in a tree have the same type if they are at even distance from one another. Adding that two vertices of opposite sign have the same type if they are at even codistance, we obtain an equivalence relation (with two classes) on the vertices of $T_+ \sqcup T_-$ [RT94, p. 406]. Two thick trees (i.e. two trees where all vertices have degree at least 3) related by a codistance are isomorphic and biregular because any two vertices of the same type have the same degree [RT94, Proposition 1]. We denote the types

by 0 and 1 and write them as subscripts when needed. Note that we do not require automorphisms of twin trees to be type-preserving. We denote by A° the subgroup of A of all type-preserving automorphisms of (T_\pm, δ^*) . Obviously, $[A : A^\circ] \leq 2$.

Let x_0^+ and x_1^+ be two adjacent vertices in T_+ . We can choose two vertices x_0^- and x_1^- such that x_i^+ and x_i^- are opposite, $i \in \{0; 1\}$: these vertices will be called the *standard positive* or *negative* vertices of type 0 or 1, accordingly. A pair of geodesic lines $L_\pm \subset T_\pm$ is called a *twin apartment* if any vertex in $L := L_+ \cup L_-$ has a unique opposite in L . By [RT94, Proposition 3.5] there is a unique twin apartment containing the four standard vertices, which we call the *standard twin apartment*. It follows from the axioms of a codistance that the codistance between two vertices of opposite sign in a twin apartment is the distance between any of the two points to the unique opposite of the other one in the twin apartment.

A straightforward consequence of (Codist) is a monotonicity property distinguishing a subfamily of geodesic rays and boundary points in each tree [RT94, 3.1–3.4]: for each pair of non-opposite vertices x_+ and y_- there is a unique ray in T_+ (resp. in T_-) emanating from x_+ (resp. y_-) along which the codistance from y_- (resp. x_+) is increasing. This defines a unique point $\zeta(x_+)_{y_-}$ of the ideal boundary $\partial_\infty T_+$ and a unique point $\eta(y_-)_{x_+}$ of the ideal boundary $\partial_\infty T_-$, so that the rays are $[x_+; \zeta(x_+)_{y_-})$ and $[y_-; \eta(y_-)_{x_+})$. Using a standard pair of opposite vertices x_i^\pm , we see that the above monotonicity arguments naturally define in T_\pm a union of geodesic rays, which we call the *standard infinite star of type i* and which we denote by $\text{St}^\infty(x_i^\pm)$. The number of rays from x_i^\pm in $\text{St}^\infty(x_i^\pm)$ is the valency of this vertex.

4.3.2. Root groups and Moufang condition

The root system Φ attached to an arbitrary Coxeter system is defined in [Tit87, Sect. 5] or in [Hum90, II.5]. We are interested in the specific case where the Coxeter group is the infinite dihedral group $D_\infty = \mathbf{Z}/2 * \mathbf{Z}/2$, say with generators s_0 and s_1 . The associated Coxeter complex is the tiling of the real line \mathbf{R} by the segments $[n; n + 1]$, $n \in \mathbf{Z}$. Let s_0 (resp. s_1) be the reflection $x \mapsto -x$ (resp. $x \mapsto 2 - x$). The *roots* of Φ are the half-lines defined by the integers, the positive ones being those containing $[0, 1]$. Each vertex has type 0 or 1, the boundary of a root is called its *vertex*, and the *type* of a root a is the type of its vertex. Two roots a and b are *prenilpotent* with one another if $a \subseteq b$ or $b \subseteq a$ [Tit87]. Let $a_0 := [0; +\infty)$ and $a_1 := (-\infty; 1]$ be the roots whose intersection is the edge $E := [0; 1]$. A useful viewpoint on twin apartments is to see them as two Tits cones of the same Weyl group glued along their tip [Rem02b, 5.3.2]. In our case, a twin apartment is the double cone generated by the above tiling of the real line. We recover the geodesics L_\pm as the affinizations of the double cone. A *twin root* generated by a root a of any sign is then the half-plane bounded by the line passing through the origin and the vertex of a , and containing a . We denote it by a , too. Two twin roots generated by prenilpotent roots a and b are also called prenilpotent.

For a single building, the *Moufang condition* is discussed in detail in [Ron89, §6]. For twin trees it is introduced in [RT94, pp. 475–476] as follows. Let a be a twin root in the twin apartment L . Let us denote by U_a the group of automorphisms of (T_\pm, δ^*) fixing the half twin apartment a and every edge having a vertex in the interior of a .

By [RT94, Proposition 4.1], the group U_a acts freely on the set of twin apartments containing a , but it may be trivial. If the action is transitive we say that U_a is a *root group*.

Definition 59. We say that a twin tree (T_{\pm}, δ^*) satisfies the Moufang property or is a Moufang twin tree if there is a twin apartment L in which U_a is a root group for each twin root $a \subset L$. We denote by Λ the subgroup of A° generated by the root groups U_a .

The definition seems to depend on the choice of a twin apartment, but if a twin tree is Moufang, then Λ is transitive on the set of twin apartments [RT94, Proposition 4.5]. Note that so far the roles of the trees T_+ and T_- are symmetric. The Moufang property says that the valency at a vertex v is 1 greater than the order of the root group attached to a twin root whose boundary contains v , so the trees are locally finite if and only if the root groups are finite, in which case the pointwise fixator of a twin apartment, which we denote by H , is finite too. We now introduce a subgroup of Λ for which the symmetry doesn't hold any longer.

Definition 60. We denote by $\text{Stab}_\Lambda(x_\epsilon)$ (where $\epsilon \in \{+, -\}$) the stabilizer in Λ of any point $x_\epsilon \in T_\epsilon$. We use Γ instead of $\text{Stab}_\Lambda(x_\epsilon)$ when x_ϵ is the vertex x_0^- or x_1^- and the choice of one of these two points is clear.

The group $\text{Stab}_\Lambda(x_\epsilon)$ naturally acts on the tree of sign $-\epsilon$. Since Λ acts edge-transitively on T_- , up to conjugacy the possible Γ -actions are those of $\text{Stab}_\Lambda(x_0^-)$, of $\text{Stab}_\Lambda(x_1^-)$ and of their intersection $\text{Stab}_\Lambda([x_0^-; x_1^-])$. Henceforth, we fix a vertex $v_- := x_i^-$, $i \in \{0; 1\}$, and consider the corresponding Γ -action on the positive tree T_+ . The subgroup generated by the root groups U_a indexed by the twin roots a containing v_- is a finite index subgroup of $\Gamma = \Lambda(v_-)$.

Picture 61.

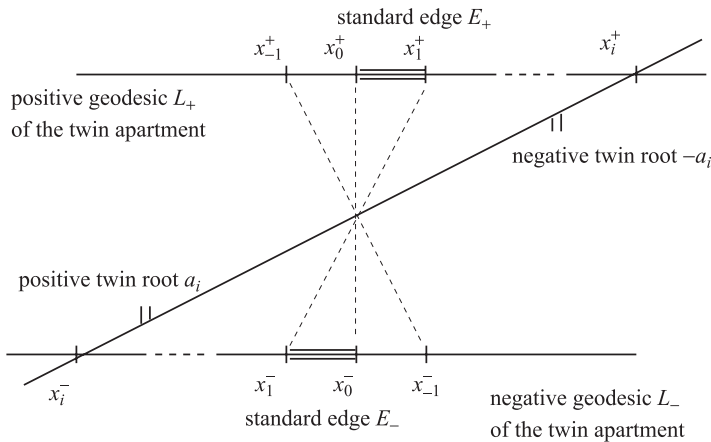

4.3.3. Connection with lattices of Nagao type

Let us first recall the technical condition on Moufang twin trees already stated in the introduction.

Definition 62. We say that a Moufang twin tree (T_{\pm}, δ^*) , or the associated group Λ , satisfies condition (Comm) if any two root groups U_a and U_b commute whenever a and b are different, prenilpotent twin roots.

We can now formulate the result relating Moufang twin trees and lattices of Nagao type.

Proposition 63. Let (T_{\pm}, δ^*) be a thick locally finite Moufang twin tree. Let A be its automorphism group and let Λ be the subgroup generated by the root groups. We fix a twin apartment L_{\pm} , a pair of opposite vertices $v_{\pm} \in L_{\pm}$, and we denote by Γ the group $\text{Stab}_{\Lambda}(v_{-})$. For each sign $\epsilon = \pm$, we number $\{v_j^{\epsilon}\}_{j \in \mathbf{Z}}$ the vertices of L_{ϵ} in such a way that $v_0^{\epsilon} = v_{\epsilon}$ and for any j , v_j^{ϵ} and v_{j+1}^{ϵ} are neighbours and v_j^{ϵ} and $v_j^{-\epsilon}$ are opposite. For each $j \in \mathbf{Z}$, we denote by V_j (resp. U_j) the positive (resp. negative) root group associated to the twin root whose boundary is $\{v_j^{+}; v_j^{-}\}$, and we denote by E_{+} (resp. E_{-}) the edge $[v_0^{+}; v_1^{+}]$ (resp. $[v_0^{-}; v_1^{-}]$).

- (i) Any of the two geodesic rays $\{v_j\}_{j \geq 0}$ and $\{v_j\}_{j \leq 0}$ from v_{+} is a fundamental domain for the Γ -action on T_{+} .
- (ii) The stabilizer $\text{Stab}_A(E_{+} \cup \{v_{-}\})$ is finite, and in particular so is $H_0 := \text{Stab}_{\Gamma}(E_{+})$. Moreover we have the decomposition: $\text{Stab}_{\Gamma}(v_j) = H_0 \times (U_1, \dots, U_j)$ for each $j > 0$, and the stabilizer $\text{Stab}_{\Gamma}(v_0)$ is the finite group generated by H_0 and the root groups indexed by the two opposite twin roots bounded by v_{-} and v_{+} .
- (iii) The group Γ , as well as its action on T_{+} , identifies with the group and the action attached to the graph of groups of Picture 4.1, where the geodesic ray is $\{v_j\}_{j \geq 0}$ and the groups are the above stabilizers.
- (iv) The group Γ is a T_{+} -lattice of Nagao type, which is of directly split Nagao type whenever (T_{\pm}, δ^*) satisfies (Comm).
- (v) The level function on the positive vertices is nothing else than the codistance from the Γ -fixed negative vertex v_{-} , that is: $\ell(x) = \delta^*(v_{-}, x)$ for any $x \in VT_{+}$.

Proof. Recall that two edges are called *opposite* if the two corresponding pairs of vertices of opposite signs and same type are pairs of opposite vertices. According to [Tit92, Proposition 7], the groups A and Λ both admit a structure of RGD-system [Tit92, 3.3], also called a twin root datum – see also [Abr97, I, Definition 2] or [Rem02b, Chapter 1]. To the RGD-system is naturally attached a positive (resp. negative) Tits system whose Borel subgroups are the stabilizers of the edges in T_{+} (resp. in T_{-}) [Abr97, §1, Proposition 1]. The group Γ is a parabolic subgroup of the negative Tits system and (i) is a special case of [Abr97, §3, Corollary 1], which applies to general Moufang twin buildings.

We have $\delta^*(v_1^{+}, v_0^{-}) = 1$ because v_1^{+} and v_1^{-} are opposite and v_1^{-} and v_0^{-} are neighbors. Since L_{\pm} is a twin apartment, v_1^{-} is the only neighbor of v_0^{-} in L_{-} which is opposite v_1^{+} , so that v_{-1}^{-} is the only neighbor of v_0^{-} to be at codistance 2 from v_1^{+} . Therefore the positive root group V_0 acts transitively on the neighbors of v_0^{-} which are $\neq v_{-1}^{-}$. Let $h \in \text{Stab}_A(E_{+} \cup \{v_{-}\})$; by the previous sentence, we can find $u \in V_0$ such that $u^{-1}h \in \text{Stab}_A(E_{+} \cup E_{-})$, so that $\text{Stab}_A(E_{+} \cup \{v_{-}\}) = V_0 \cdot \text{Stab}_A(E_{+} \cup E_{-})$.

Finally, the finiteness of $\text{Stab}_A(E_+ \cup E_-)$ follows from Ronan–Tits’ rigidity theorem [RT94, Theorem 4.1], which says that the identity is the only twinning automorphism which fixes E_+ , E_- and all the edges having a vertex in common with E_+ . Since $\Lambda < A$, this obviously implies the finiteness of $H_0 = \text{Stab}_\Gamma(E_+)$. The rest of (ii) is a special case of Levi decompositions of stabilizers of pairs of points of opposite signs in twin buildings [Rem02b, 6.3.4].

For a general Moufang twin tree, the group U_1, \dots, U_i is in bijection with the set $U_1 \times \dots \times U_i$, and it is isomorphic to the direct product group $U_1 \times \dots \times U_i$ whenever (Comm) is satisfied: this proves (iv), once we note that (iii) is a classical consequence of Bass–Serre theory [Ser77, I.4.5, Théorème 10]. At last, (v) follows from the fact that the two functions $\ell(\cdot)$ and $\delta^*(v_-, \cdot)$ coincide on the ray $\{v_j\}_{j \geq 0}$ and are constant on each Γ -orbit. \square

Remark 64. In terms of twin root data (or, equivalently, of RGD-systems), the group Δ of 4.2.1 is the unipotent radical of the negative parabolic subgroup Γ , and the decomposition $\Gamma = \Gamma_0 \ltimes \Delta$ is a Levi decomposition [Rem02b, 6.2.2]. The fundamental domain F of Lemma 35 is the union of the level-increasing rays from v_+ : it is the infinite star $\text{St}^\infty(v_+)$ defined purely in terms of codistance in 4.3.1.

Recall that two subgroups of a given group are *commensurable* if they share a finite index subgroup.

Lemma 65. *With the same notation as above, we have:*

- (i) *For any two points $x, x' \in T_-$, the groups $\text{Stab}_A(x)$ and $\text{Stab}_A(x')$ are commensurable.*
- (ii) *For any point $x \in T_-$, we have $A = \text{Aut}(T_\pm, \delta^*) < C(\Gamma)$.*
- (iii) *The group $C(\Gamma)$ acts transitively on geodesics of given length and type in T_+ , and it acts transitively on geodesics of given length if T_+ has a type-exchanging automorphism.*

Proof. For any $x \in T_-$, we can choose an edge E whose closure contains v , and in this case we have: $\text{Stab}_{A^\circ}(E) <_{\text{f.i.}} \text{Stab}_A(x)$. Therefore, in order to prove (i) it is enough to consider the case when x and x' both belong to the interior of an edge, say E for x and E' for x' . Let y (resp. y') be the midpoint of E (resp. E'), and let δ be the distance between y and y' . Let g be an arbitrary automorphism of T_+ stabilizing the edge E . Then $g \cdot y'$ is at distance δ from y and when g is type-preserving, the geodesic from y to $g \cdot y'$ leaves E through the vertex through which the geodesic from y to y' leaves E . Using root groups for roots containing E , we see for any $g \in \text{Stab}_{G^\circ}(E)$, the edge $g \cdot E'$ is a $\text{Stab}_\Lambda(E)$ -transform of E' . Since T_- is locally finite, we have a finite set of such edges, say $h_1 \cdot E', \dots, h_N \cdot E'$ with $h_1, \dots, h_N \in \text{Stab}_\Lambda(E)$. Therefore $\text{Stab}_{G^\circ}(E) = \bigsqcup_{j=1}^N h_j (\text{Stab}_{G^\circ}(E) \cap \text{Stab}_{G^\circ}(E'_j))$, so that $\text{Stab}_{A^\circ}(E) \cap \text{Stab}_{A^\circ}(E') <_{\text{f.i.}} \text{Stab}_{A^\circ}(E)$. Switching x and x' and using the first remark, we obtain (i). Moreover (ii) follows from (i) since $g\text{Stab}_G(x)g^{-1} = \text{Stab}_G(g \cdot x)$ for any $g \in G$. The subgroup Λ already enjoys the transitivity property of the first assertion of (iii) (this is true in the general twin building case [Abr97, §2, p. 28]), and the second assertion is easily deduced from the first one. \square

We can finally turn to the proof of our second main result.

Proof of Theorem 7. We choose (T_{\pm}, δ^*) a thick locally finite Moufang twin tree satisfying (Comm), and go on using the notation of the previous two results. By Proposition 63 (iv), the lattice Γ is of directly split Nagao type. The closure group $\overline{C(\Gamma)}$ contains $\overline{C(\Gamma)} \cap L$, which is equal to L by Theorem 4. But $\overline{C(\Gamma)}$ also contains Λ , in which many elements do not preserve the level function ℓ . To see this, we note that by Proposition 63 (v) we have: $\ell(x) = \delta^*(v_-, x)$ and $\ell(g \cdot x) = \delta^*(g^{-1} \cdot v_-, x)$ for any $x \in VT_+$ and any $g \in A$. In order to have $\ell(x) \neq \ell(g \cdot x)$, it is enough to make $x := v_+$ and to pick an element $n \in N_{\Lambda}(L_{\pm})$ lifting a reflection in a vertex x_j with $j \neq 0$ (which always exists e.g. according to [Abr97, §2, Lemma 4 (ii)]). Finally it remains to apply Proposition 20 to the group $F = \overline{C(\Gamma)}$, which contains $L \cup \Lambda$. \square

4.3.4. Examples

Let us now give examples of Moufang twin trees from the most familiar to the most exotic ones. We first note that according to M. Ronan and J. Tits [RT99, Corollary 8.2], a thick semihomogeneous tree whose set of vertices has cardinality α , belongs to 2^α isomorphism classes of twinings, among which most of them have no automorphism. The examples below are all required to be Moufang (in particular, have big automorphism groups).

Example 66. There is a detailed study of $\Lambda = \mathrm{PSL}_2(\mathbf{F}_q[t, t^{-1}])$ in [RT94, §2]. Let M be a rank 2 free $\mathbf{F}_q[t, t^{-1}]$ -lattice with basis $\{u; v\}$, and let T_+ and T_- be the Bruhat-Tits trees of $\mathrm{SL}_2(\mathbf{F}_q((t)))$ and $\mathrm{SL}_2(\mathbf{F}_q((t^{-1})))$, respectively [Ser77, II.1]. The vertices in T_+ , resp. in T_- , are the homothety classes of $\mathbf{F}_q[[t]]$ -lattices, resp. of $\mathbf{F}_q[[t^{-1}]]$ -lattices, in the vector space $M \otimes_{\mathbf{F}_q[t, t^{-1}]} \mathbf{F}_q((t))$, resp. in $M \otimes_{\mathbf{F}_q[t, t^{-1}]} \mathbf{F}_q((t^{-1}))$. The codistance is defined in [RT94, Lemma 2.1]. A useful subset of vertices in T_+ is given by the homothety classes of the lattices $\mathbf{F}_q[[t]]u \oplus \mathbf{F}_q[[t]]t^jv$ for $j \in \mathbf{Z}$, and similarly in T_- replacing t by t^{-1} . The convex hull of these vertices in T_+ is a geodesic L_+ , and together with the similar convex hull L_- in T_- , they form a twin apartment L . The pointwise fixator H of L_{\pm} is the finite subgroup of diagonal matrices with coefficients in \mathbf{F}_q^{\times} . The Nagao lattice $\Gamma = \mathrm{PSL}_2(\mathbf{F}_q[t^{-1}])$ lies in Λ and the latter group acts edge-transitively on each tree. It can actually be proved by hand that for each $d \in \mathbf{Z}$, the group $\left\{ \begin{pmatrix} 1 & \lambda \cdot t^d \\ 0 & 1 \end{pmatrix} : \lambda \in \mathbf{F}_q \right\} \simeq (\mathbf{F}_q, +)$ is the root group attached to the root a_d defined as the convex hull of the homothety classes of the lattices $\mathbf{F}_q[[t]]u \oplus \mathbf{F}_q[[t]]t^jv$ for $j \geq d$. The union of these root groups when d ranges over \mathbf{Z} is the unipotent radical of the upper triangular Borel subgroup, and condition (Comm) holds because this unipotent group is abelian.

Example 67. Split Kac-Moody groups of rank two: these groups are defined by generators and relations in full generality in [Tit87]. The datum needed to define such a group roughly consists in a generalized Cartan matrix A and a groundfield \mathbf{K} . The rank 2 condition says that the matrix is 2×2 , the size 2 corresponding to the number of generators of the Weyl group. The diagonal entries are equal to 2, and one must require that the product of the off-diagonal entries be ≥ 4 so that the Weyl group

of the building is infinite (dihedral). Each of the off-diagonal coefficients is negative, and the group satisfies the assumption (Comm) if and only if both entries are ≤ -2 . This follows from the computation of commutator relations between root groups due, up to signs, to J. Morita [Mor88, §3, example 6]. Note that apart from the density of the commensurator for the rank 2 case, many other arguments supporting the analogy between (parabolic subgroups of) Kac-Moody groups over finite fields and arithmetic groups over function fields are given in [Rem02a].

Example 68. Twisted Kac-Moody groups are defined in [Rem02b, Part II, §11]. They are groups consisting of fixed points in a split Kac-Moody group, for a suitable Galois action. The rank 2 condition refers to the number of generators in the Weyl group. A classical example is provided by the unitary group $SU_3(\mathbf{F}_q[t, t^{-1}])$, whose twinned trees are semihomogeneous of valencies $1 + q$ and $1 + q^3$ [Rem04, §3.5]. The unipotent radicals of Borel subgroups of $SU(3)$ over $\mathbf{F}_q((t))$ or $\mathbf{F}_q((t^{-1}))$ are not abelian but only metabelian: $SU_3(\mathbf{F}_q[t, t^{-1}])$ doesn't satisfy (Comm). The example of a semi-homogeneous Moufang twin tree whose corresponding group Λ satisfies (Comm) is given for instance in [Rem02b, 13.3]. The twisted group is a subgroup of rational points in a Kac-Moody group naturally acting on buildings whose apartments are tilings of the hyperbolic plane.

Example 69. A general construction of Moufang twin trees is given in [Tit90, §9]. Its starting point are two abstract root group data of rank 1, and the classification of the latter structure is known in the finite case. As Tits showed, starting with this data, it is always possible to construct a Moufang twin tree satisfying our Condition (Comm) and having as root groups (up to isomorphism) those occurring in the original root group data of rank 1. An easy way to produce non-classical locally finite Moufang twin trees by this method was pointed out by Sh. Mozes to the second author. Taking the affine group $\mathbf{F}_l^\times \ltimes \mathbf{F}_l$ (l is any prime power) acting on the affine line \mathbf{F}_l , we obtain what Tits calls a Moufang set and hence a root group data of rank 1. We take two copies of this, and then J. Tits' method provides homogeneous Moufang twin trees with root groups isomorphic to \mathbf{F}_l^\times . This cannot occur, at least if $l - 1$ is not itself a prime power, for Bruhat-Tits or Kac-Moody trees since in the latter cases the valencies are cardinalities of projective lines.

Therefore, for instance with $l = 7$, we obtain a non-uniform tree lattice of directly split Nagao type for a regular tree of valency 7. In the latter case, the root groups are all isomorphic to $\mathbf{F}_7^\times \simeq \mathbf{Z}/2 \times \mathbf{Z}/3$. Let us use the notation of the previous subsection, in particular the T_+ -lattice Γ is the parabolic subgroup of Λ fixing a negative vertex v_- of (T_\pm, δ^*) . The subgroup H of Γ generated by the root groups indexed by the negative roots containing a given geodesic subray of L_- emanating from v_- , is isomorphic to the direct sum of these root groups. Taking the 2-torsion (resp. 3-torsion) part of H and arguing as in [Rem02a, Theorem 5], we conclude that H , hence Γ , cannot be linear over any field. In other words, we have obtained a group inclusion $\Gamma < G$ where the tree-lattice Γ is non-linear but arithmetic in a generalized sense, whereas the classical Nagao lattice is obviously linear. Of course, the construction works with any prime power l such that $l - 1$ admits two different prime divisors.

Example 70. In J. Tits' construction of the previous example, the starting point is a pair of two root group data. In the case where each root group datum comes from a PSL_2 -action on a projective line, a down-to-earth construction is made in [RR06, § 2]. This is enough to produce strictly more general Moufang twin trees than those coming from Kac-Moody groups since there may be two ground fields (one for each type of vertex). The choices of the characteristics of the ground fields can be made so that the argument of the second paragraph of the previous example enables to obtain again $\langle\langle$ non-linear but arithmetic $\rangle\rangle$ tree-lattices. At last, the concrete viewpoint allows to generalize the construction to the case of Moufang twin buildings with a Weyl group of arbitrarily large rank, leading to generalized Kac-Moody groups with strong non-linearity properties acting on two-dimensional buildings [RR06, Theorem 4.A].

References

- [Abr97] P. Abramenko, Twin buildings and applications to S -arithmetic groups, Lecture Notes in Mathematics, vol. 1641, Springer (1997).
- [BL01] H. Bass and A. Lubotzky, Tree lattices, Progress in Mathematics, vol. 176, Birkhäuser (2001).
- [BM96] M. Burger and Sh. Mozes, $\mathrm{CAT}(-1)$ -spaces, divergence groups and their commensurators, *Journal of the American Mathematical Society*, **9** (1996) 57–93.
- [Hag03] F. Haglund, Linearity and commensurability of uniform lattices of right-angled hyperbolic buildings, preprint University Paris sud, Orsay (2003).
- [Hum90] J. E. Humphreys, Reflection Groups and Coxeter Groups, Cambridge studies in advanced mathematics, vol. 29, Cambridge University Press (1990).
- [Lif03] L. Lifschitz, Arithmeticity of rank-1 lattices with dense commensurators in positive characteristic, *Journal of Algebra*, **261** (2003) 44–53.
- [Liu94] Y. Liu, Density of the commensurability group of uniform tree lattices, *Journal of Algebra*, **165** (1994) 346–359.
- [Mar91] G.A. Margulis, Discrete Subgroups of Semisimple Lie Groups, *Ergebnisse der Mathematik und ihrer Grenzgebiete (3)*, vol. 17, Springer (1991).
- [Mor88] J. Morita, Root strings with three or four real roots in Kac-Moody root systems, *Tōhoku Mathematical Journal*, **40** (1988) 645–650.
- [Moz99] Sh. Mozes, Trees, lattices and commensurators, Algebra, K -Theory, Groups, and Education: On the Occasion of Hyman Bass's 65th Birthday (T. Y. Lam and A. R. Magid, eds.), Contemporary Mathematics, vol. 243, American Mathematical Society (1999) pp. 145–151.
- [Rem02a] B. Remy, Classical and non-linearity properties of Kac-Moody groups, Rigidity in Dynamics and Geometry (Newton Institute, 2000) (M. Burger and A. Iozzi, eds.), Springer-Verlag (2002) pp. 391–406.
- [Rem02b] B. Remy, Groupes de Kac-Moody déployés et presque déployés, *Astérisque*, vol. 277, Société Mathématique de France (2002).
- [Rem04] B. Remy, Kac-Moody groups: split and relative theories. Lattices, Groups: Geometric and Combinatorial Aspects (Bielefeld 1999) (Th. Müller, ed.), London Math. Soc. Lecture Note Series, vol. 311 (2004) pp. 487–541.
- [Ron89] M. Ronan, Lectures on Buildings, Perspectives in Mathematics, vol. 7, Academic Press (1989).
- [RR06] B. Remy and M. Ronan, Topological groups of Kac-Moody type, right-angled twinings and their lattices, *Comm. Math. Helv.*, **81** (2006) 191–219.
- [RT94] M. Ronan and J. Tits, Twin trees I, *Inventiones Mathematicæ*, **116** (1994) 463–479.

- [RT99] M. Ronan and J. Tits, Twin trees II, Local structure and a universal construction, *Israel Journal of Mathematics*, **109** (1999) 349–377.
- [Ser77] J.-P. Serre, Arbres, amalgames, SL_2 , *Astérisque*, vol. 46, Société Mathématique de France (1977).
- [Tit87] J. Tits, Uniqueness and presentation of Kac-Moody groups over fields, *Journal of Algebra*, **105** (1987) 542–573.
- [Tit90] J. Tits, Théorie des groupes, *Annuaire Collège de France (Résumé de cours)* (1990) pp. 87–103.
- [Tit92] J. Tits, Twin buildings and groups of Kac-Moody type, *Groups, Combinatorics & Geometry (LMS Symposium on Groups and Combinatorics, Durham, July 1990)* (M. Liebeck and J. Saxl, eds.), *LMS Lecture Notes Series*, vol. 165, Cambridge University Press (1992) pp. 249–286.